

**Primary Switched Charging and Power Supply Unit GL4024 24V - 28V, 40A**

**3-Wire Supply**

**Hat-rail mounting**

**Convection heating**



- 3-Wire AC 340 – 550V 47-63Hz
- Soft start
- Long product lifetime
- Long-term short-circuit resistance (fold back)
- Overheating protection
- Safety cutoff
- Interference class acc. to curve B
- Low output ripple

**Application:**

The battery charging and power supply unit GL4024 is used for charging high-quality lead or nickel-cadmium batteries and/or for supplying 24V DC circuits. The charging unit is especially suitable for use with diesel generators, where operating safety and long-term stability are necessary.

The primary clocked switching power supply with 100kHz technology is intended for use on the top-hat rail due to its high efficiency, low weight and low heat development. It is designed such that heat transport is vertical, meaning that other electronic units can be mounted on the hat rail about 5-15cm away from the power supply unit (depends on amount of heat), thus saving space.

The output of the GL4024 is connected to the battery or DC supply via protective equipment. The output voltage / final charging voltage is also kept stable during large mains fluctuations (340 - 550VAC) and high temperature variations.

When the unit is operated for longer periods at high currents and in heated environments, the charging current set is reduced automatically in order to reduce the thermal load on the components.

**Charging:**

**Normal Charging:**

The empty battery is first charged at the constant current set. Before the preset final charging voltage is reached, the current gradually decreases. The gassing of the battery is limited and the continually reduced current causes the voltage to rise slowly until it reaches the final charging voltage. This characteristic I / U curve ensures the gradual charging of the battery.

**Settings etc.:**

The GL4024 charging unit is set to a battery voltage of 26.6V in no-load operation before leaving the factory. The final charging voltage is adjusted in no-load operation using the adjuster on the bottom of the unit.

In mounting you should make sure that the PE connection (earthing clip) is connected so that the unit meets the interference requirements according to VDE and EN (see below).

The LED display on the front panel indicates that the charging and power supply unit is ready for operation (output voltage present). We recommend an additional battery undervoltage monitor for precise monitoring of the battery voltage when the GL4024 is used as a battery charging unit.

**We recommend to choose the unit power output by + 30% to guarantee utmost availability.** For example: Power of your application 600W, Unit Output Power 1.3 x 600W = 780W.

## Series / Parallel Connection:

The output current can be increased by connecting GL4024 units in parallel (no battery charging and no maximal load). Parallel connecting of different types of units are not allowed. In order to ensure correct parallel operation, the open load voltage must be set to same values. Series connecting of units are only allowed with additional current limitation up to rated current (no maximal load).

### Technical Data :

Type	Final charging Voltage Range	Current Max.	AC Current on mains (max)	Fusing Prim. (Q1) acc. to EN60 898	Fusing Sec. (Q2)	Weight	Dimensions (mm , W x H x D)
GL4024	24 - 28V	40A	2,4A (400V) 1,9A (500V)	10A B (400V)	50A B	3,3kg	276x125,2x100

Mounting	: 35mm Hat rail TS-35/7,5 or 15mm
Supply	: 340 – 550V 47 – 63Hz
Inrush consumption max.	: 50A/400VAC
Lost current	: <3,5mA / 530V
Efficiency	: 91%
Output voltage	: Range 24 – 28V, Hum and Noise <80mVpp
Output current	: 0 – 40A (rated)
Final charging voltage	: Tolerance 0,01% / °C
Charging characteristics	: IU – Char. inspired by DIN 41773 and DIN 57510 with reduced Current (Wa) in the area of final charging voltage (appr. 3,5% of setting)
Soft start	: Appr. 284ms up to maximum output power
Overload	: 105 – 150% of rated output current (40A) according mains voltage and output voltage : overtemperature- and current limiting, Short circuit proofed, with Fold-back function : independent switch on after short circuit or overload
Over voltage	: 30 -36V, automatic swich off and switch on again
Ambient temperature	: -20°C up to +50°C , see derating-diagramm
Storing temperatures, hum.	: -40°C up to +85°C, 10 – 96%RH
Relative air humidity	: 20 – 90% RH not condensed
Vibration	: 10 – 500Hz, 2G 10min./1 period, 60min. in each axis X, Y, Z
Type of protect., Connections	: IP00, Input connections each 4 qmm, Output connections each 3 x 4 qmm
Terminal torque / Wire	: 0.7 N.m / copper only, mimimum 80°C wire
Maintenance	: No
Service live	: > MTBF 122.500 hours , MIL HDBK-217F (25°C)
Safety standard	: EN60950
Voltage protection	: Mains / Output 3kVAC, Mains / Screen 1,5kVAC, Output / Screen 0,5kVAC
Isolation resistance	: Mains / Output , Mains / Screen and Output / Screen 100MΩ/ 500VDC
Radio Interference	: EN55011, EN55022 (CISPR22), EN61204-3 Kl. B
Harmonic Currents	: EN 61000-3-2, -3
Interference Immunity	: EN61000-4-2,3,4,5,6,8,11, ENV50204, EN61204-3, EN61000-6-2 (EN50082-2) Very heavy industrial environment, criterion A

### Connecting example / Derating diagrams

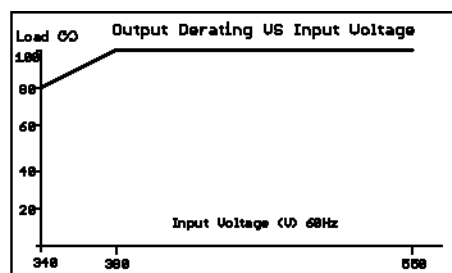
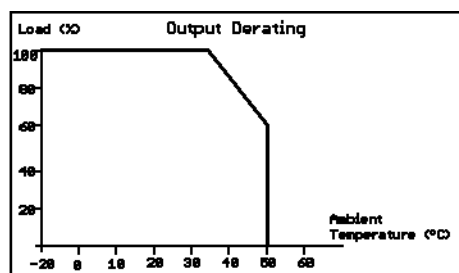
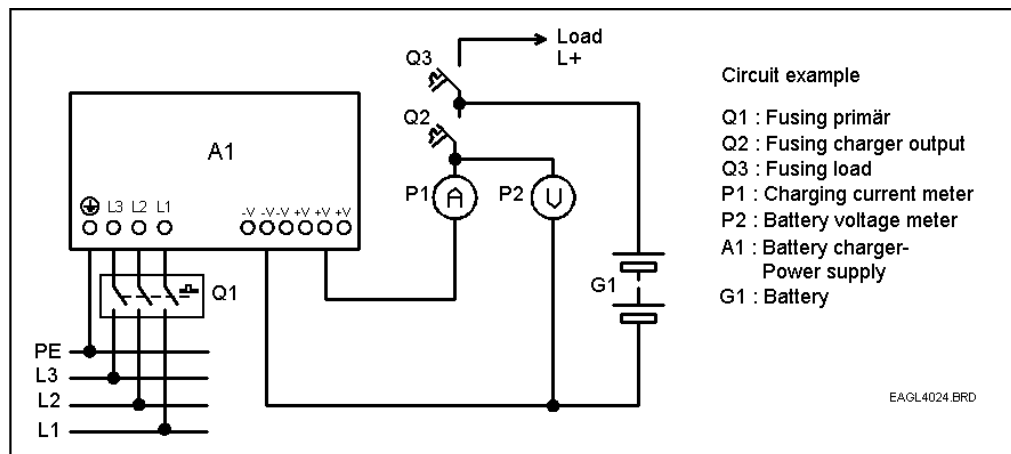

**Note for wiring power supplies and chargers of the GL-Series**

