

GL4024P Primary Switched Battery Charging and Power Supply Unit with DC On/Ready Contact



- Compact design for DIN rail mounting
- Battery charging and low voltage supply
- Output voltage adjustable
- DC On (Power Ready) Contact
- LEDs for DC On and DC Low
- Parallel operation
- Power Factor PFC 0,7
- Efficiency factor 92 %
- Operating temperature range -25 ... +71 ° Celsius

Application:

The battery charging and power supply unit GL4024P is used for charging high-quality lead or nickel-cadmium batteries and/or for supplying 24V DC circuits. The charging unit is especially suitable for use with diesel generators, where operating safety and long-term stability are necessary.

The primary clocked switching power supply is intended for use on the top-hat rail due to its high efficiency, low weight and low heat development. It is designed such that heat transport is vertical, meaning that other electronic units can be mounted on the hat rail about 5-15 cm away from the power supply unit (depends on amount of heat), thus saving space.

The output of the GL4024P is connected to the battery or DC supply via protective equipment. The output voltage / final charging voltage is also kept stable during large mains fluctuations (3x 340 - 575 VAC) and high temperature variations.

When the unit is operated for longer periods at high currents and in heated environments, the charging current set is reduced automatically in order to reduce the thermal load on the components.

Charging:

Normal Charging:

The empty battery is first charged at the constant current set. Before the preset final charging voltage is reached, the current gradually decreases. The gassing of the battery is limited and the continually reduced current causes the voltage to rise slowly until it reaches the final charging voltage. This characteristic I / U curve ensures the gradual charging of the battery.

Settings, DC On Contact, etc.:

The GL4024P charging unit is set to a battery voltage of 26.6V in no-load operation before leaving the factory. The final charging voltage is adjusted in no-load operation using the adjuster on the front of the unit.

In mounting you should make sure that the PE connection is connected so that the unit meets the interference requirements according to VDE and EN.

The LED's on the front panel indicates that the charging and power supply unit is ready for operation (DC On or DC Low). **An additional DC On contact allows the monitoring of the charger. At fault (DC Out > = 17.6 to 19.4 V) opens the normally open contact.**

We recommend choosing the unit power output by + 30% to guarantee most availability.

Technical Data:

Input

Nominal voltage	3× AC 400–500 V
Operation voltage range	3× AC 340–575 V; 3× DC 480–820 V
Line frequency	47 Hz – 63 Hz
Rated current	U _i = AC 400 V: 2.4 A / U _i = AC 480 V: 1.6 A
Inrush current	30 A
Internal fuse	T6, 3 A / per phase
External fuse	Automatic: 3 × B 16 A, C 10 A
Power Factor Correction P.F.C.	0.7

Load Side

Rated voltage output	DC 24 V
Rated current output	40 A
Voltage trim range	22.5–28.5 V
Accuracy	1 %
Line regulation	±1 %
Load regulation	Single ±1 %, Parallel ±5 %
Rise time	1 s
Temperature coefficient	±0.03 % / °C
Ripple & Noise	80 mV

Hold up time	15 ms
Status indication DC ON LED green	≥17.6–19.4 V
Status indication DC LOW LED red	≤17.6–19.4 V
Parallel/redundant operation	max 2 devices with 92 % load current each, connection P and G for distributed current
Efficiency	92 %
Rated over load protection	Rated over load protection: 110 % –130 %
Over voltage protection	125–137 %
Short circuit characteristics	Hiccup-mode

General

Switching frequency	approx. 52 kHz
Insulation voltage input/output	AC 3.0 kV _{eff}
Insulation voltage input / ground	AC 1.5 kV _{eff}
Insulation resistance at DC 500 V	100 MΩ
Operation temperature range	-25 °C – 71 °C (derating)
Derating	-3.5% / °C starting at 61°C
Storage temperature range	-25 °C – 85 °C
M.T.B.F.	352000 h
Relative humidity	20–90% RH, non-condensing
Dimensions (w × h × d)	276.0 × 125.0 × 118.0 mm
Cooling	Natural air cooling, 25 mm distance on all sides
Installation position	vertical
Housing material	metal
Protection class	IP 20
Field installation	rail TS 35 (EN 50022)
Application height	3000 m
IP rating	I (SELV, PELV)
Overvoltage category	II
Pollution degree	2
Weight (kg/piece)	3.200
Termination	Screw terminal: 0.5–10.0 mm ² , max. 0.62 Nm
Approvals	TÜV: EN 62386-1; CE: EN 61000-6-3 / EN 55022 Class B, EN 61000-3-2, EN 61000-3-3, EN 61000-6-2, EN 55024 Class I, Division 2, Groups A, B, C and D

Monitoring

DC ON Control (Rdy)	Normally open
Switching voltage	DC 60 V
Switching current	max. 300 mA
Insulation voltage	DC 500 V

Dimensions

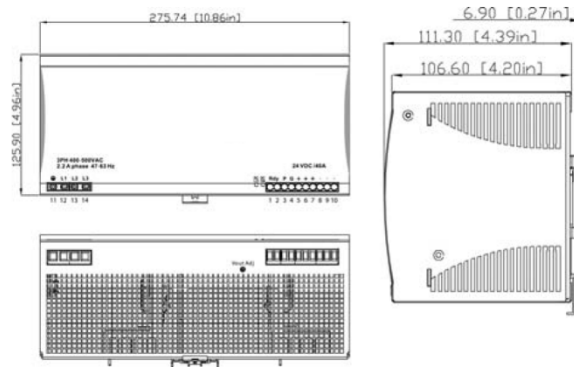

PIN assignment

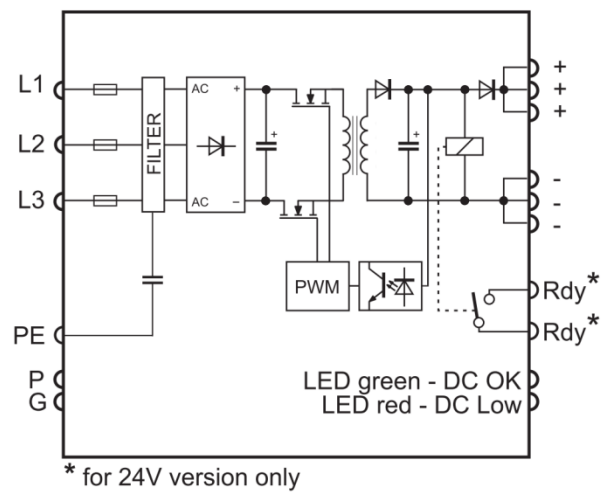

Derating

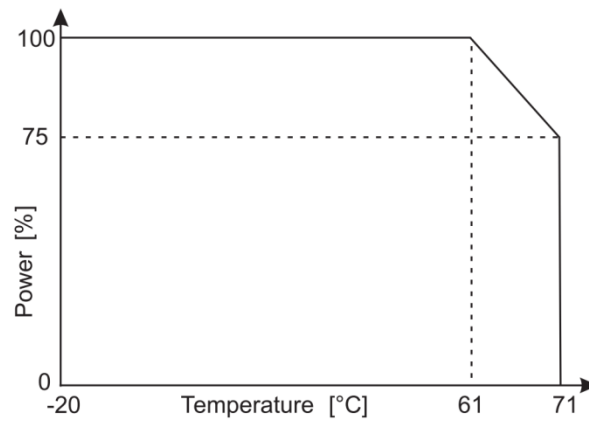

Parallel Mode:

Parallel mode is only available in mains operation and not in charging mode using two identical devices.
The parallel connection of different Units is not allowed!

Parallel/redundant mode

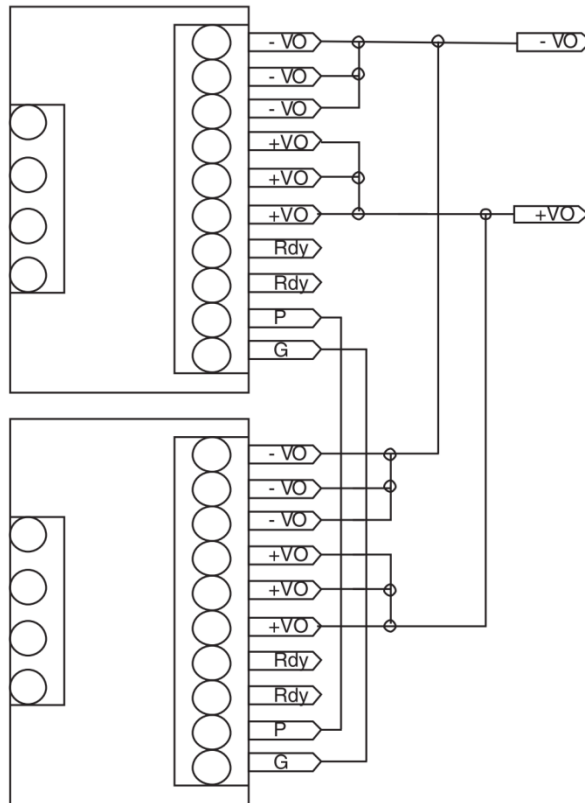

Short circuit characteristics

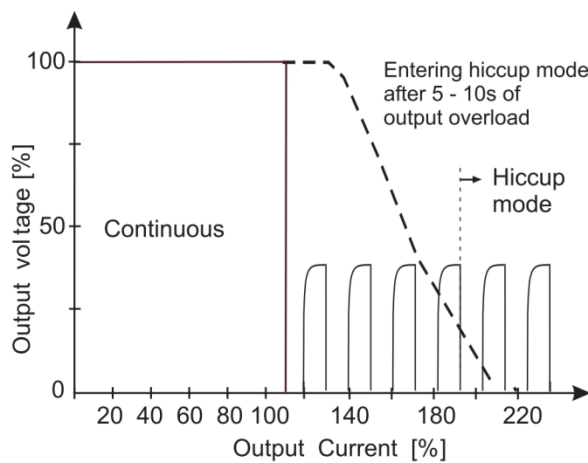

Important Note:

When charging on generators with an integrated alternator, a blocking diode must be connected between the GL4024P and the battery. Failure to comply will void all guarantee claims.