

M2100 Emergency Controller

The ultimate solution to emergency generator controls

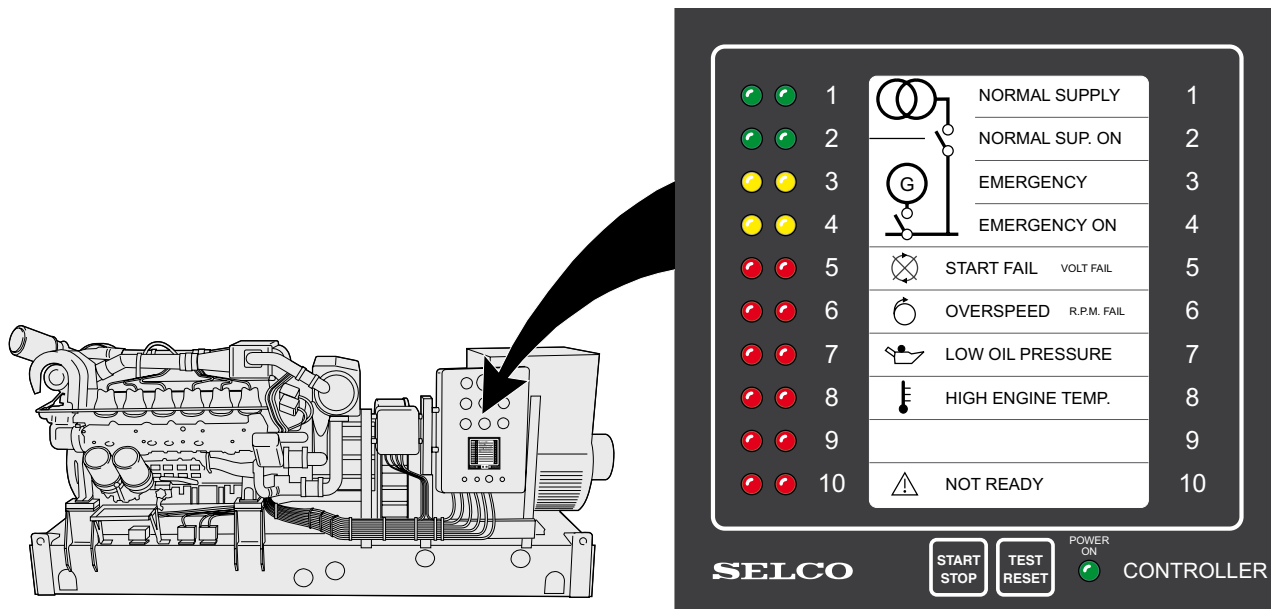

- Fulfills the requirements of NFPA 110 1985
- Compact unit for switchboard front panel mounting with standard instrument dimensions of 144 x 144 and a depth of only 35 mm
- Withstands severe 4 g vibration test 5-100 Hz
- Two powerful LEDs for each of the 10 indicating channels which have been provided with sign windows for easy insertion of identification labels
- Internal tacho relay and programmable check of external circuit
- Quick installation by means of clamp fittings and plug-in terminal blocks for easy service
- Micro-computer based circuit, especially designed for high noise immunity and high supply voltage variations
- 16 contacts for programming functions and delays
- Possibility of transfer back via synchronizer, without interruption of supply
- Contains automatic test and intermittent prelubrication
- Indicates directly, if all conditions for automation emergency supply are present
- Auxiliary options: Battery back-up M0100. Tacho-voltage detector M0500. Watertight cover M0800.

Function

The SELCO M2100 Emergency Controller has been designed to take care of the complete control of an emergency generator. It controls start and stop of the engine, monitors the engine and the transfer during start and operation, and simultaneously indicates - on the front - all necessary information about the conditions of the emergency generator. In case of loss of normal supply the unit will be activated via an external voltage relay.

If activated during the entire start delay period (2-4-10-15 sec.) the start will be initiated. It is possible to select up to 4 start attempts, with both crank and rest periods adjustable (5-7-10-15 sec.).

When the engine has started, a signal from an internal or external tacho relay (crank disconnect) detects in excess of 33% of the nominal frequency, and the cranking will be disconnected. When the generator voltage has reached 90%, the unit activates, and after engine warm-up period (0.5-2-4-10 sec.) has expired the normal supply is disconnected and 0.5 sec. later the emergency supply is connected.

When the normal supply returns, and is maintained in the entire "return-to-normal" period (1-2-4-10 min.) the emergency supply is disconnected and 0.5 sec. later the normal supply is connected.

The engine runs unloaded in the cool-off period (0-3-10-30 min.) before shut down.

Besides above main functions the controller contains many other features.

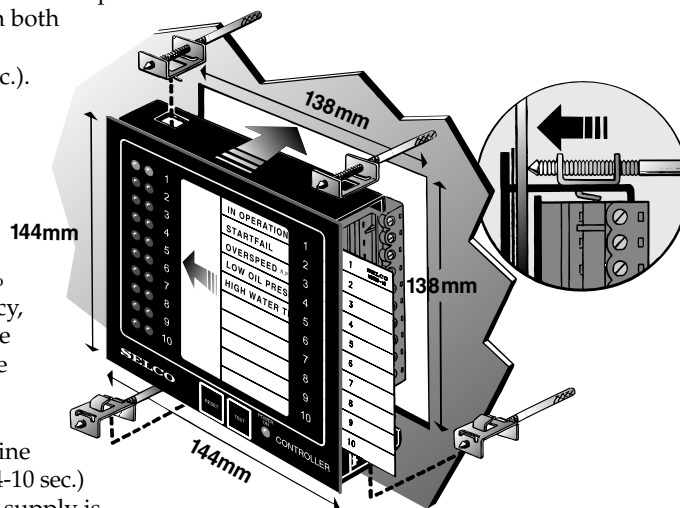

Quick and easy replacement of text label

Inputs

- Terminal 1: VOLTAGE RELAY
NO contact to minus. The voltage relay that monitors the normal supply is connected here. Will initiate the emergency sequence. If the contact disconnects again within the start delay period, the emergency sequence is interrupted.
- Terminal 2: EMERGENCY TEST
NO contact to minus. A continuous signal will carry through the test of the emergency sequence, except for the transfer of the load. Is terminal 1 activated during the test, the normal emergency sequence is carried out. Is terminal 2 connected to 22 then an automatic test is carried out once a week.
- Terminal 3: MODE
An external 3-position switch is connected here.
MANUEL (MAN.). Is obtained by connecting terminal 3 to plus, and in that position start and stop can only be performed via the push button on the front.
AUTOMATIC (AUT.). Is obtained with terminal 3 open and in that position the normal emergency supply sequence is performed via input 1.
OFF. Is obtained by connecting terminal 3 to minus, and in this position the engine is stopped and blocked for start.
WARNING: Is OFF considered as safety switch-off, then output 18 (CRANK) must also be disconnected.
- Terminal 4: NOT READY
NO contact to minus. To this terminal one or more external signals can be connected with functions that are necessary for the emergency generator to operate ; e.g. an alarm annunciator with pre-alarms, a minimum fuel tank level monitor or a battery charge monitor. When activated LED 10 "NOT READY" will indicate and output 23 will be activated.
- Terminal 5. NORMAL SUPPLY CIRCUIT BREAKER. NB! NC contact to minus. Connected to a normally closed auxiliary contact on the normal supply circuit breaker. Will be indicated on LED 2 on the front.
- Terminal 6. EMERGENCY SUPPLY CIRCUIT BREAKER. NO contact to minus. Connected to a normally open auxiliary contact on the emergency circuit breaker.
- Terminal 7:
GENERATOR VOLTAGE RELAY
NO contact to minus. This input is to be activated when the generator has reached normal voltage and/or frequency, indicating that the generator can be loaded. If the signal fails to appear within 15 sec. after receipt of crank disconnect there will be given alarm and a steady light on LED 5 is indicating generator voltage failure.
- Terminal 8: TACHO INPUT
Connected to terminal 3 on M0500. Here the generator frequency is measured via the attached tacho voltage detector M0500 if contact S15 is activated. 33% of the nominal frequency (system frequency 50 or 60 Hz chosen on terminal 9) is crank disconnect. Above 90% will allow loading of the generator and 114% is overspeed. In the first 8 sec. after start, the overspeed limit is increased to 120%. Leave this input open if M0500 is not used.
- Terminal 9: CRANK DISCONNECT / SYSTEM FREQUENCY.
NO contact to minus. With programming contact S15 ON, an external contact-signal is connected here, for instance a tacho relay indicating that the engine is running. If the programming contact S15 is OFF, the internal tacho function (M0500) is active, and the system frequency is programmed on this terminal as follows :
9 to minus = 60 Hz, 9 open = 50 Hz.
- Terminal 10: OVERSPEED
NO contact to minus. Here an external tacho relay set for the engine overspeed is connected. Will give shut-down and flashing of LED 6 labelled "OVERSPEED". This input terminal is also active together with the internal tacho detector (M0500).
- Terminal 11: REMOTE ACCEPT / RESET / LAMP TEST. NO contact to plus. Used in connection with failures on the engine. First activation disconnects the siren. Second activation stops the flashing and releases the blocking. Every time there is an activation, all LEDs will light as lamp test. Same function as RESET / LAMP TEST push button on the front.
- Terminal 12. SYNCHRONIZE BACK / NORMAL SUPPLY INSTANTLY OFF. Programming terminal with two functions.
 1. By synchronizing back from emergency supply to normal supply without disconnection an external synchronizer is activated by output 24.
This synchronizer connects the normal supply, and 0.2 sec. later the emergency supply is tripped automatically via input 5 and output 26.
In this situation circuit breakers with mechanical or electrical interlock cannot be used.
 2. In the standard sequence the normal supply is not disconnected until the emergency supply is ready to be loaded, but there is a possibility of tripping the normal supply immediately when the engine starts to crank. This is called "NORMALLY SUPPLY INSTANTLY OFF".
Programming :
12 to plus gives synchronize back
12 to minus gives normal supply instantly OFF
12 to minus through a 3.3 kΩ resistor, gives both normal supply instantly OFF and synchronize back
12 open excludes both functions
- Terminal 13: LOW OIL PRESSURE
NO contact to minus. The input is enabled 8 sec. after crank disconnect. Here a lubrication oil pressostat is connected. Gives shut-down and flashing on LED 7 labelled "LOW OIL PRESSURE".
Contains possibility of circuit check or alarm by connecting input 16 to minus and mounting 3.3 kΩ across the contact. If this connection is broken or opened an alarm will be indicated by slow flashing LEDs.
Circuit check failure or alarm is enabled 8 sec. after crank disconnect and gives steady light on LED 7.
To ensure start by emergency generators and to avoid that the starter can be engaged when the motor is running alternative crank disconnecting signal is available via this input.

After each start attempt - before a new start attempt - the oil pressure is checked. Is there an oil pressure the motor must be running or the oil pressure created from cranking is remaining and new cranking is avoided.
If oil pressure is detected low within 30 sec. cranking continues but is the oil pressure still high after 30 sec. the

engine must be running and an alarm and a R.P.M. failure indication are given to show that the tachometer input is out of order and that the over-speed protection may be out of function.

- Terminal 14: HIGH WATER TEMPERATURE. NO contact to minus. The input is enabled 8 sec. after crank disconnect. Here a cooling water thermostat is connected. Gives shut-down and flashing on LED 8 labelled "HIGH WATER TEMPERATURE". Contains possibility of circuit check or alarm by connecting input 16 to minus and mounting 3.3 kΩ across the contact. If this connection is broken or opened an alarm will be indicated by slow flashing LEDs. Circuit failure or alarm is enabled 8 sec. after crank disconnect and gives steady light on LED 8.

- Terminal 15: SPARE
The input is enabled 8 sec. after crank disconnect. This input is intended for any extra motor protection function. Gives shut-down and flashing on LED 9. Contains possibility of circuit check or alarm by connecting input 16 to minus and mounting 3.3 kΩ across the contact. If this connection is broken or opened an alarm will be indicated by slow flashing LEDs. Circuit failure or alarm needs no enabling and gives steady light on LED 9.
- Terminal 16: OVERRIDE / CIRCUIT CHECK
Programming terminal with two functions.
 1. Override means that motor protection (shutdown) connected to terminal 13, 14, and 15 is out of function. To be used in situations where stop cannot be accepted or

where supply is necessary in spite of a failure. Override is indicated by LED 10 "NOT READY" flashing.

2. Circuit check demands a resistor 3.3 kΩ installed directly across the monitoring contacts connected to terminals 13, 14 and 15. A small current will now run in the circuit, and is circuit check active and is this small current disconnected, it will be indicated on the appropriate channel together with an alarm signal. This circuit can also be used for pre-alarms, with the same name as the labels on the front, by installing a normally closed alarm contact in series with the resistor. Programming :
 - 16 to plus gives override
 - 16 to minus gives circuit check
 - 16 to minus via 3.3 kΩ gives both override and circuit check
 - 16 open excludes both functions

Outputs

- Terminal 17: PREGLOW
Is activated when 1 is activated and remains activated in the start delay and cranking period. Intended for preglow or pre-lubrication.
- Terminal 18: CRANK
Is activated in the cranking sequence. Here a relay is connected, which activates the engine starter.
- Terminal 19: FUEL VALVE / STOP SOLENOID Here a relay is connected which - with the contact S16 closed - will control the diesel engine's fuel valve, meaning that it is active, as long as the engine starts and runs, and will be deactivated at stop of the engine (energize-to-run). With S16 disconnected a signal is obtained which - by stop - will activate a stop solenoid with a duration of 20 sec. (energize-to-stop).
- Terminal 20: RUNNING
Becomes active after receiving crank disconnect and deactivates at motor-stop. Can be used to enable an external alarm panel M1000 for pre-alarms.
- Terminal 21: EMERGENCY SUPPLY FAIL. Becomes active at following fails : Start fail, shut-down due to fail. In general, all fails causing the emergency set not to be able to supply. Is intended for signalling start to an extra emergency set.
- Terminal 22: EXERCISER 2 MIN. / WEEK.
Becomes active 2 min. per week and starts one week after the supply has been connected to M2100. By connecting this terminal to terminal 2, an automatic test is carried out once a week. See also under terminal 2.
- Terminal 23: NOT READY
Will be activated by connecting terminal 4 to minus, and if LED 5 to 9 is flashing or if mode switch is in MAN. or OFF position. Same function as LED 10. Can be used for remote indication.
- Terminal 24: SYNCHRONIZER ENABLE
Can be used to enable an extra synchronizer which performs the transfer-back without disconnection by synchronizing the emergency generator to the normal supply. Is only active when programmed on 12.
- Terminal 25: AUXILIARY LUBE PUMP
Becomes active for 2 min. for every 30 min., when the engine is stopped. Is used for continuous lubrication. Immediately after stop, the first lubrication period is 20 min.
- Terminal 26: EMERGENCY SUPPLY ON
Here a relay is connected activating the emergency supply circuit breaker. Delayed 0.5 sec. after the normal supply circuit breaker trip, when transferring to emergency supply.
- Terminal 27: NORMAL SUPPLY OFF
Here a relay is connected. When activated will trip the normal supply circuit breaker. Delayed 0.5 sec. after the emergency supply circuit breaker, when transferring back to normal supply. If the transfer delay is not wanted this signal can be used for controlling both circuit breakers at the same time.
- Terminal 28: + SUPPLY
Positive supply of 12 or 24V DC. 12V type can be ordered especially.
- Terminal 29: - SUPPLY
Negative supply of 12 or 24V DC. 12V type can be ordered especially.
- Terminal 30, 31 and 32: ALARM CONTACT
Separate contact for siren. Relay normally activated. Without supply voltage ON or by failures there will be connection between 30 and 31. Under normal conditions with supply voltage ON there will be connection between 31 and 32.

Front Plate

- **LED 1: NORMAL SUPPLY**
Indicates when input contact 1 is disconnected. Shows that normal supply is present.
- **LED 2: NORMAL SUPPLY ON**
Indicates when input 5 is OFF and shows that the normal supply circuit breaker is ON.
- **LED 3: EMERGENCY GEN.**
Is indicating with steady light when crank disconnect is present and shows that the diesel engine is running. Flashes fast by cranking. Flashes slowly at rest periods and at start delay.
- **LED 4: EMERGENCY C / B ON**
Indicates when input 6 is activated and shows that the emergency supply circuit breaker is ON.
- **LED 5: START FAIL (VOLTAGE FAIL)**
Flashes when all start attempts have been accomplished without crank disconnect signal is received. Goes on steady light (voltage fail) if 7 does not arrive within 15 sec. or if 7 disappears without a stop signal received, thus indicating voltage fail.
- **LED 6: OVERSPEED (R.P.M. FAIL)**
Flashes by activating 10 and if via M0500 the frequency exceeds 115%. Goes on steady light if 9 is disconnected or if M0500 frequency passes below 33% without a stop signal received, thus indicating R.P.M. failure. R.P.M. failure means either unwanted engine stop or failure in the speed detection which indicates that the overspeed protection is perhaps not active.
- **LED 7: LOW OIL PRESSURE**
Flashes by activation of input terminal 13. If circuit check or alarm is activated, failure gives steady light.
- **LED 8: HIGH WATER TEMPERATURE**
Flashes by activating input terminal 14. If circuit check or alarm is activated, failure gives steady light.
- **LED 9: SPARE**
Can be used for an extra protection signal. Flashes by activating input terminal 15. If circuit check or alarm is activated, failure gives steady light.
- **LED 10: NOT READY**
Indicates if the emergency set is ready to run automatically. Indicates with steady light if terminal 4 is connected to minus or if LED 5 to 9 is flashing or the switch connected to 3 is in MAN. or OFF position. Same function as terminal 23.
- **SINGLE GREEN LED POWER**
Will indicate when 24V or 12V supply is connected.
- **PUSH BUTTON START / STOP**
Every second time it is pushed start respectively stop of the diesel engine is obtained. Only active in MAN. mode.
- **PUSH BUTTON ACCEPT / RESET / LAMP TEST**
First push by failure disconnects the siren. Second push disconnects flashing and blocking, and allows the engine to start again. Works as lamp test when it is pushed. Like input terminal 11.

Programming Switches / Rear side

- **Contact S1 + S2: START ATTEMPT**
Here 1 - 4 start attempts can be selected

ATTEMPTS	1	2	3	4
S1	ON	OFF	ON	OFF
S2	ON	ON	OFF	OFF
- **Contact S3 + S4: CRANK TIME**
Here the crank duration can be programmed. If only one start attempt is selected the crank duration is extended to 3 times the selected crank time.

SEC.	5	7	10	15
S3	ON	OFF	ON	OFF
S4	ON	ON	OFF	OFF
- **Contact S5 + S6: REST TIME**
Here the time between start attempts is programmed.

SEC.	5	7	10	15
S5	ON	OFF	ON	OFF
S6	ON	ON	OFF	OFF
- **Contact S7 + S8: START DELAY**
Here the time is programmed, from terminal 1 is activated until cranking is started. This is repeated ahead of all start attempts.

SEC.	2	4	10	15
S7	ON	OFF	ON	OFF
S8	ON	ON	OFF	OFF
- **Contact S9 + S10: ENGINE WARM UP**
Here the time is programmed, from terminal 7 (gen. freq. and volt. OK) is activated until transfer and load of the emergency set.

SEC.	0.5	2	4	10
S9	ON	OFF	ON	OFF
S10	ON	ON	OFF	OFF
- **Contact S11 + S12: RETURN TO NORMAL TIME**
Here the time is programmed, from input terminal 1 is deactivated (normal supply OK) till transfer back to normal supply.

MIN.	1	2	4	10
S11	ON	OFF	ON	OFF
S12	ON	ON	OFF	OFF
- **Contact S13 + S14: COOL DOWN TIME**
Here the time is programmed where the diesel engine runs unloaded before it is stopped.

MIN.	0	3	10	30
S13	ON	OFF	ON	OFF
S14	ON	ON	OFF	OFF
- **Contact S15: TACHO DETECTING**
Here input contacts on 7, 9 and 10 or external M0500 tacho detector can be selected.

S15 ON = TACHO INPUT 8 OFF (contact inputs)
 S15 OFF = TACHO INPUT 8 ON AND M0500 CONNECTED
- **Contact S16: FUEL VALVE / STOP SOLENOID**
The unit is here adapted to the engine's stop system. Is the engine supplied with a fuel valve, which is activated at stop, or is the engine supplied with a stop solenoid, which is activated for 20 sec. at stop ?

S16 ON = FUEL VALVE (energize-to-run)
 S16 OFF = STOP SOLENOID (energize-to-stop)

General Information

Circuit check or cable monitoring is obtained by installing a 3.3 kΩ resistor over the NC contact on the engine and preparing the unit by connecting 16 to minus to detect the current with resistor. If this current disappears the cable is broken and an alarm is indicated on the appropriate channel. The same function is used for alarms where a NC alarm contact in series with the resistor can generate an alarm.

The outputs have built-in flywheel diodes and are further protected against short-circuit with a limitation of 1 Amp. If the current is exceeded, the appropriate output is disconnected until the output is reactivated - continuous current max. 150mA per output. Incandescent lamps can activate the protection current, as the starting circuit can be 10 times the normal current, but a small bias circuit can normally solve the problem (resistor from output to minus). To ensure that cranking is not signalled

when the motor is running, the following safety functions are included:

- 1) Is the crank disconnect signal or the high lube oil pressure present cranking cannot be activated.
- 2) If the crank disconnect signal disappears during run and no stop signal is received, either because the engine has been stopped directly or the tacho detection is defective, the cranking is blocked and alarm signal and steady light on overspeed is given (indicates that overspeed protection is prospectively not present). Now the start cannot be repeated until 20 sec. have expired after receiving a stop signal. This is to ensure that the engine is stopped completely before cranking.
- 3) It is tested - after each start attempt, before a new start attempt - if oil pressure is present. If so, the engine can be running and further cranking will be avoided, unless the oil pressure goes low within 30 sec.

WARNING: It must be emphasized that

the part of the engine protection signalling via the terminals 13, 14 and 15 is disconnected at override. It is only to be used in emergency situations where stop cannot be accepted or where supply is necessary in spite of a failure. Override is indicated by LED 10 "NOT READY" flashing.

Primary control circuit

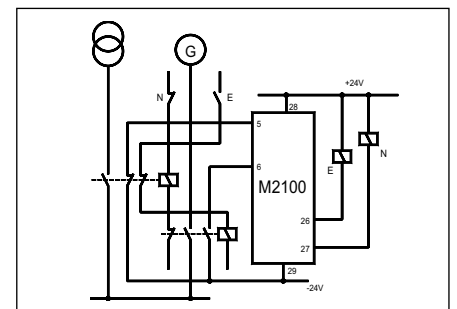

Fig. 2. Primary Control Circuit.

Input terminals

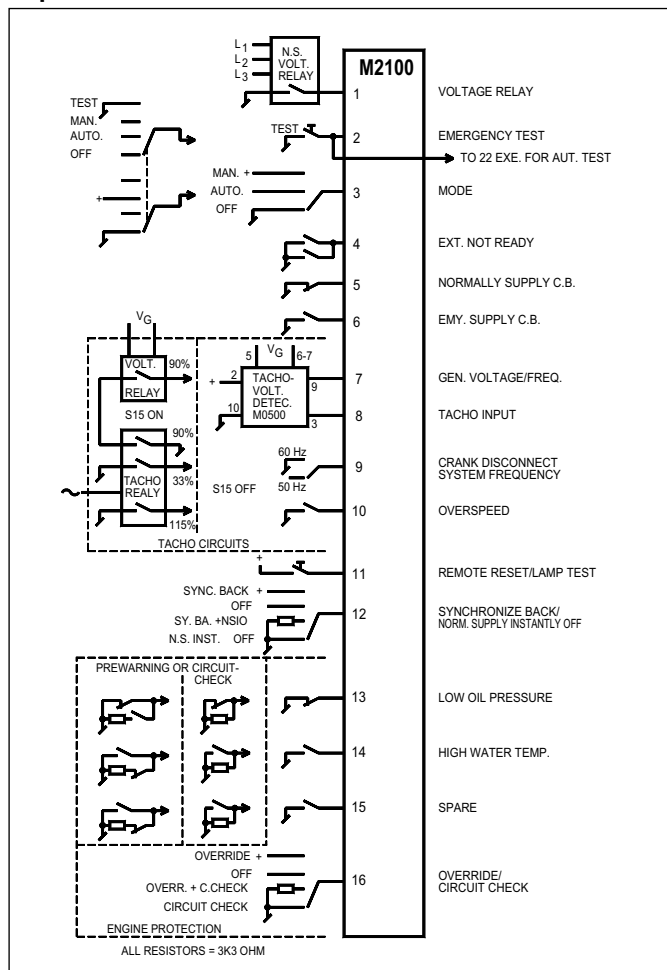

Fig. 3. Input Terminals.

Output- and supply terminals

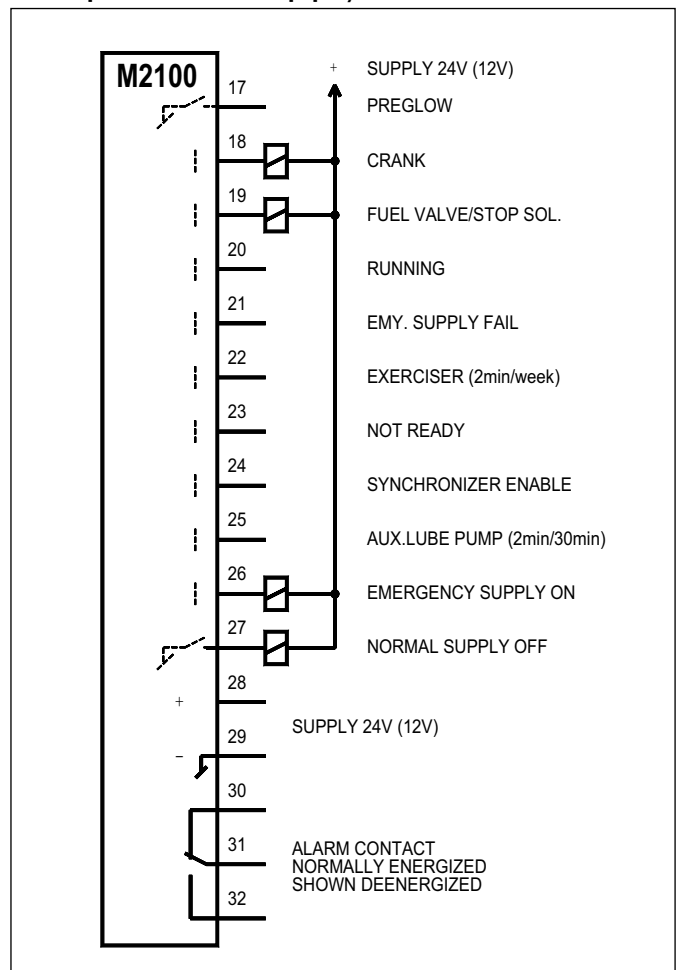

Fig. 4. Output and Supply Terminals.

Specifications

M2100 Emergency Controller

Type Approvals and Certificates

The SELCO M2100 has been designed and tested for use in harsh environments. The input and output terminals include circuitry especially designed to protect the unit from electric noise and high level voltage spikes. The unit is based on standard components providing long term durability. The M2100 unit carries the CE label and has been approved by the major marine classification societies.



- American Bureau of Shipping
- Bureau Veritas
- Croatian Register of Shipping
- Det Norske Veritas
- Germanischer Lloyd
- Lloyds Register of Shipping
- Nippon Kaiji Kyokai (ClassNK)
- Registro Italiano Navale
- Romanian Register of Shipping
- Russian Maritime Register of Shipping

SELCO Worldwide



Voltage Supply	M2100-10B: 12V DC -70% / +30% M2100-20B: 24V DC -70% / +30%
Consumption on terminals 28-29	0.25A
Output contact	Siren 220V AC / 2A 30V DC / 2A / 30W
Outputs	Max. 0.15A per output continuous Max. 0.5A peak
Noise immunity	IEC 255-4/Class 2 SS 436 1503 PL 3
Tolerance, delays	± 2%
Tolerance, frequency measuring	± 2%
LED flash frequency	Slow Flashing Light: 1.25Hz ± 10% Quick Flashing Light: 5Hz ± 10%
Operating temperature	-10° to +70°C
Dimensions	144 x 144 x 35 mm (HxWxD)
Weight	0.5kg

The specifications are subject to change without notice.

Programming table

Start attempts					Return to normal				
	1-	2-	3-	4 attempts		1-	2-	4-	10 min.
S1	on	off	on	off	S11	on	off	on	off
S2	on	on	off	off	S12	on	on	off	off
Crank time					Cool down				
	5-	7-	10-	15 sec.		0-	3-	10-	30 min.
S3	on	off	on	off	S13	on	off	on	off
S4	on	on	off	off	S14	on	on	off	off
1 attempt = 3 x crank time					Int. tach detection				
Rest time					S15	on = tach input off			
	5-	7-	10-	15 sec.	S15	off = tach input on			
S5	on	off	on	off	Fuel valve/stop solenoid				
S6	on	on	off	off	S16	on = fuel valve			
					S16	off = stop solenoid			
Start delay					Push-buttons				
	2-	4-	10-	15 sec.	Start - stop accept-reset-lamp test				
S7	on	off	on	off	Example of programming of delay:				
S8	on	on	off	off	S7 off and S8 on will provide start delay of 4 sec.				
Engine warm up									
	0.5-	2-	4-	10 sec.					
S9	on	off	on	off					
S10	on	on	off	off					

Main office:
 Betonvej 10
 DK- 4000 Roskilde
 Denmark
 Phone: + 45 7026 1122
 Fax: + 45 7026 2522
 e-mail: selco.dk@selco.com
 www.selco.com

